

ANTENNA MOUNTING SET AETM160-6

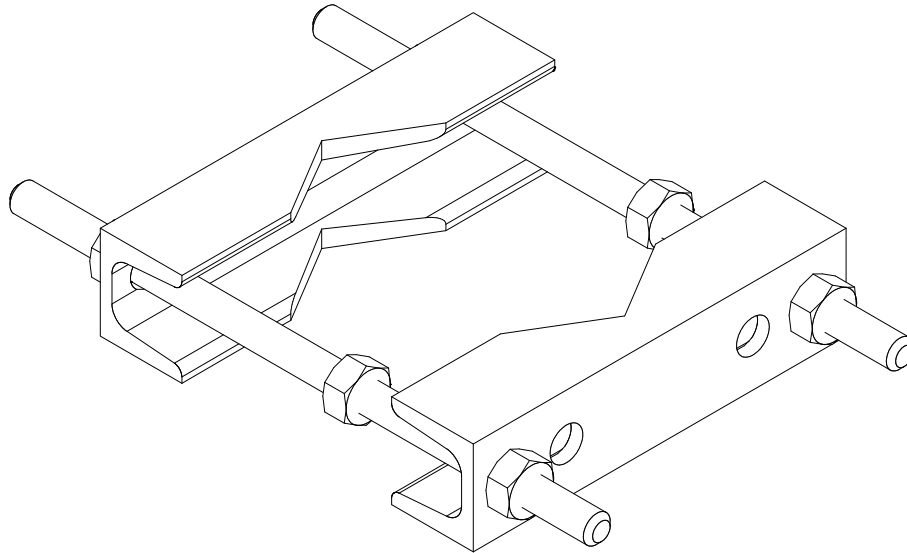

Parts list	pcs
U40-160 clamp	2
M12x250 headless screw	2
M12 nut	6

Type	AETM160-6
Dimensions (H x W x D) (Ø x H)	See above drawing
Weight	1,0 kg per point
Mounting diameter	30...115 mm pipe
Materials	Hot dip galvanized steel
Versions	-
Options	With lightweight clamp: AETM160-6-L With A2/AISI304 brackets and hardware: AETM160-6-A2 With A4/AISI316 brackets and hardware: AETM160-6-A4