

# SPECIFICATION



Description : CB SPEAKER

Model No.: TEAM TS-200

Standard : CE & RoHS

Issuing Date: Nov.09, 2011

Revised Date: Aug.05, 2013

## 1: General Description

S/N.	Item	Specification	Remarks
1--1	Product Name	External Speaker	
1--2	Rating power	3 W	4.5V
1--3	Output Impedance	4 $\Omega$	
1--4	Magnet data	Outside magnet $\Phi$ 56*13mm	
1--5	Net Weight	165 gram	
1--5	Cable	Audio $\Phi$ =3mm, L=2m	with 3.5mm mono plug
1--5	Power supply	...	

## 2: Standard Working Environment

If not specially requested, it works under below normal conditions:

Atmospheric temperature of 15~35°C, Humidity of 45-85%, and Conventional pneumatic of 860-1060 hpa

## 3: Mechanical Dimension

S/N.	Item	Specification	Remarks
3--1	Outside dimension	See attached drawing	See drawing 1

## 4: Electrical Features

S/N.	Item	Specification	Remarks
4--1	Rating Impedance	4 $\Omega$ ±15 %	50 MA/1K Hz/0.56 V
4--2	Resonance frequency	300±20% Hz	Testing single speaker
4--3	Sensitivity	89±3 dB	AT 1W/0.5M/2 V
4--4	Frequency range	FO-20KHz	OUTPUT S.P.L.±10dB
4--5	Rating output power	3W	
4--6	Max.output power	5W	
4--7	Simple audio test	Normal	Output signal at 1.3V
4--8	Abnormal sound	Normal	Sweeping at 20HZ-20KHZ, 1.3V
4--9	Audio Distortion	5% MAX	At Rating output power of 3W

## 5: Reliability Test

S/N.	Item	Specification	Remarks
5--1	Continuously load	AFTER TEST MEET ITEM 4	Operating 48 hours w/ white Noise at 3W
5--2	High Temperature Test	AFTER TEST MEET ITEM 4	Operating 48 hours at 70±2°C, 20-25% R.H.
5--3	Low Temperature Test	AFTER TEST MEET ITEM 4	Operating 48 hours at - 50°C±2°C,20-25% R.H.
5--4	Humidity Test	AFTER TEST MEET ITEM 4	25°C±2°C,90-95 % R.H.运行48小时
5--5	Withstand Voltage Test	Normal	AC 100V , 1 MIN
5--6	Insulation Resistance	Normal	DC 100V

**Drawing 1: Product Dimension**

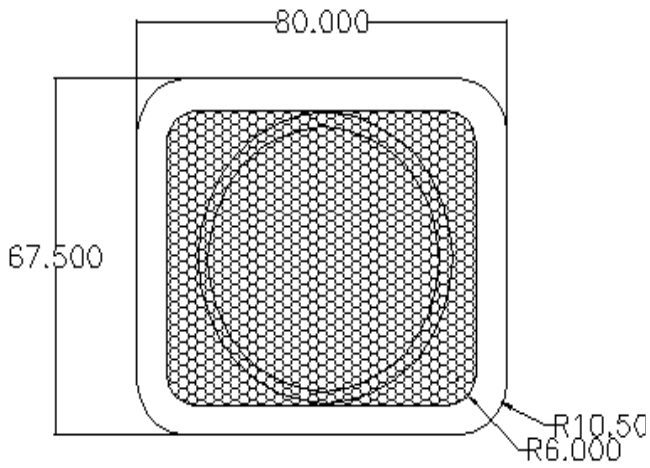

**Front View**

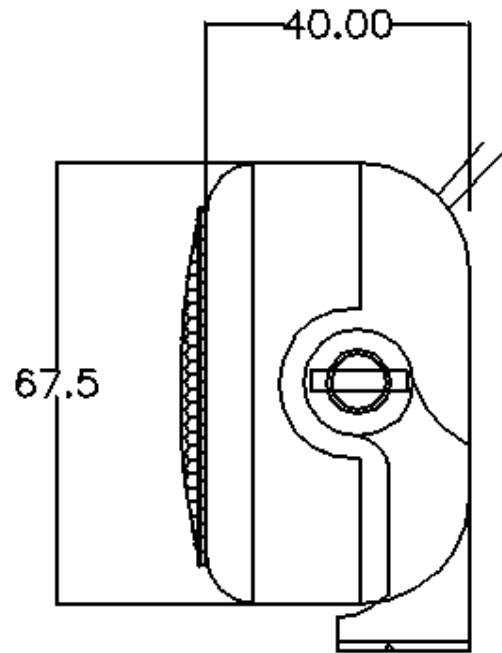

**Side View**

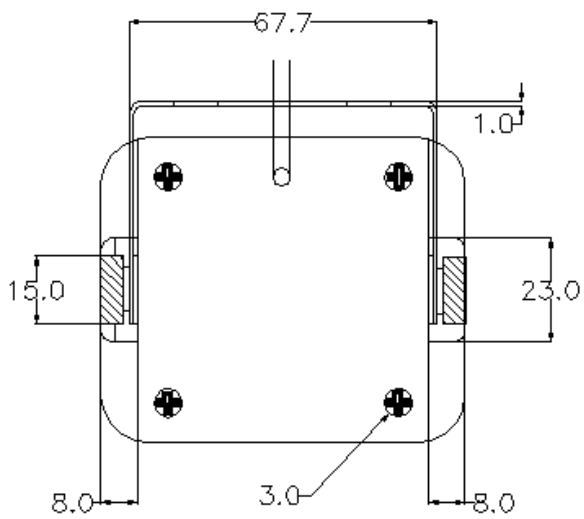

**Back View**

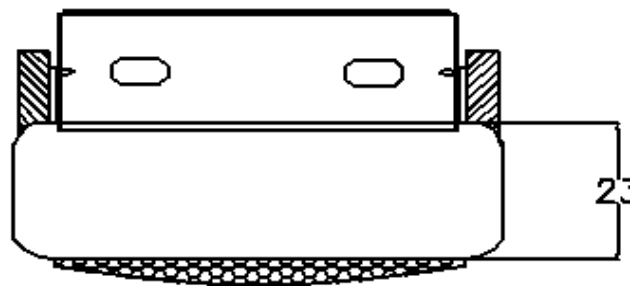

**Cable length: 2000 mm**

**Cable and Top View**

## Wiring Diagram

Drawing 2:

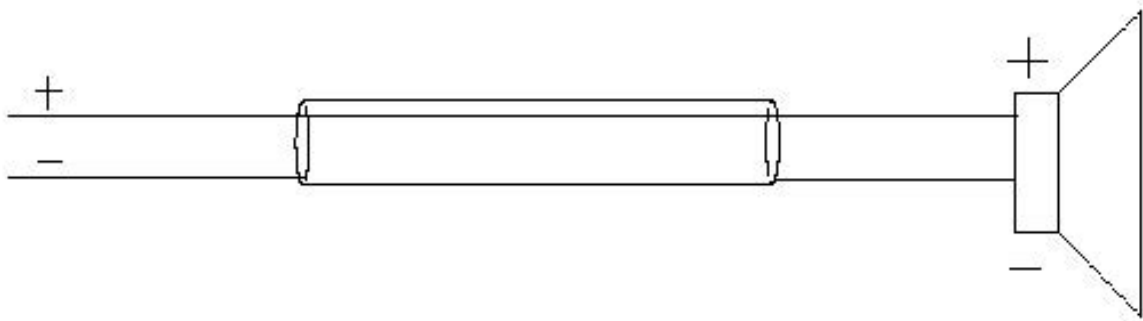

**Speaker Evaluation**  
- TS200 Team-Electronic

1.) Mechanical issues



2.) Measurement values

a. 3x Impedance and versus frequency

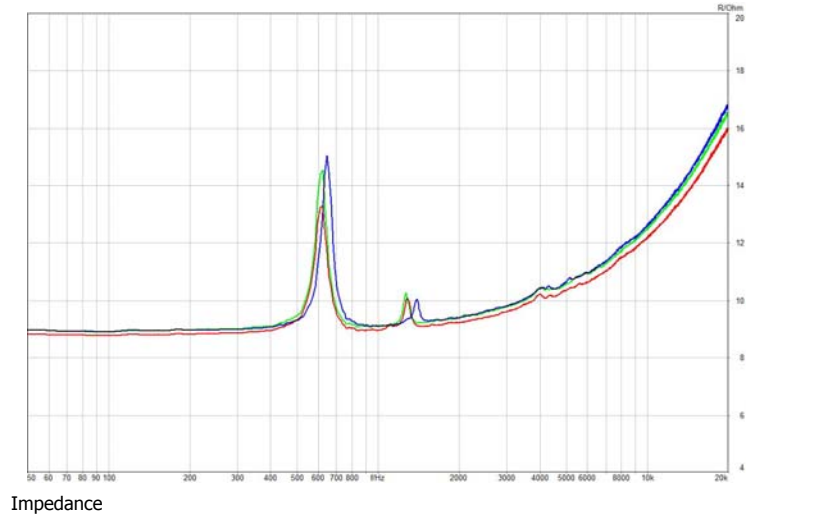

Impedance

b. 3x SPL Frequency Response @1W/1m

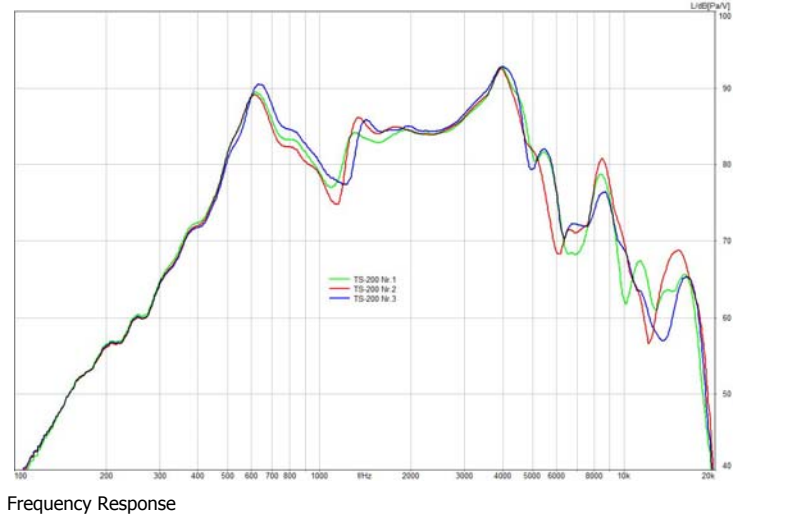

Frequency Response

c. 3x typical THD versus frequency @1W + 1x Spectrum versus time @ 1W

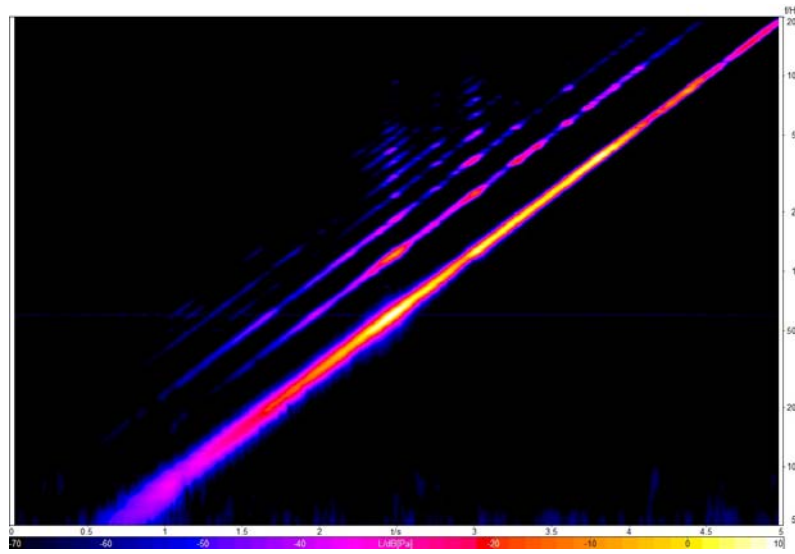
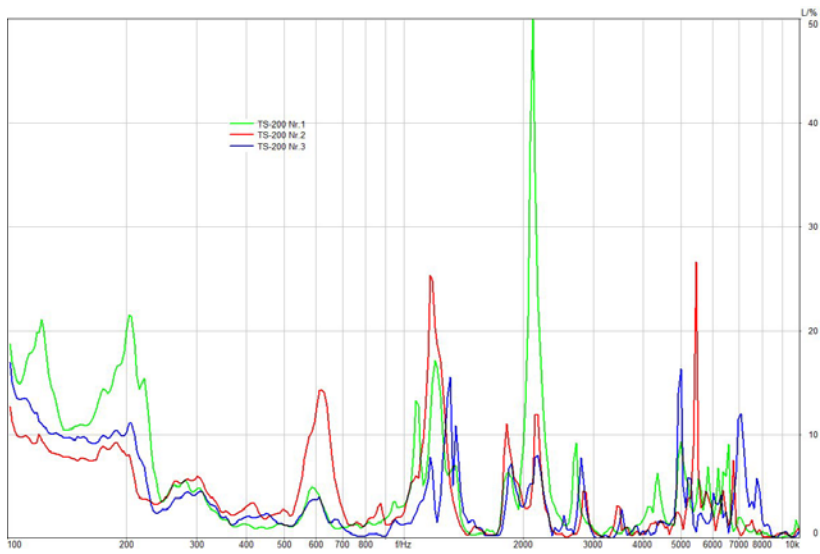

d. 15x Dual Tone 550Hz+715Hz Intermodulation Noise versus Speaker Power 0.1W up to 3W

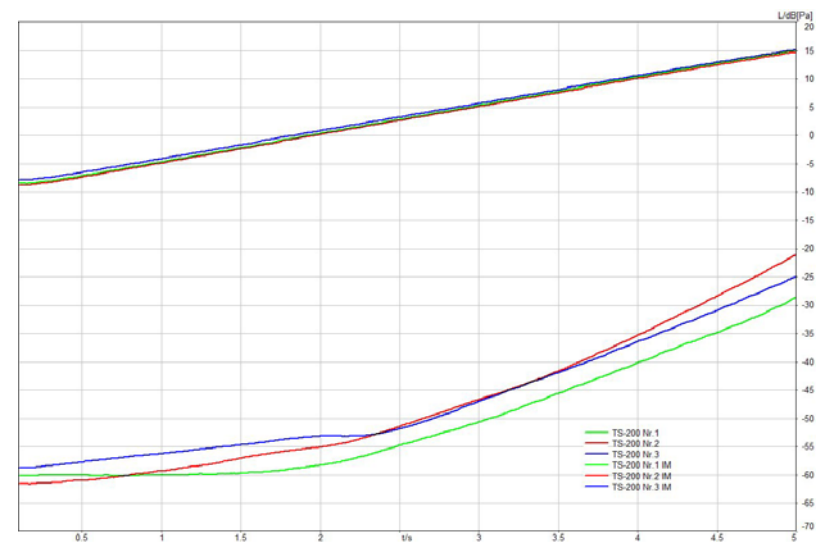

IM (550Hz+715Hz) Noise Level (10mW bis 3W)

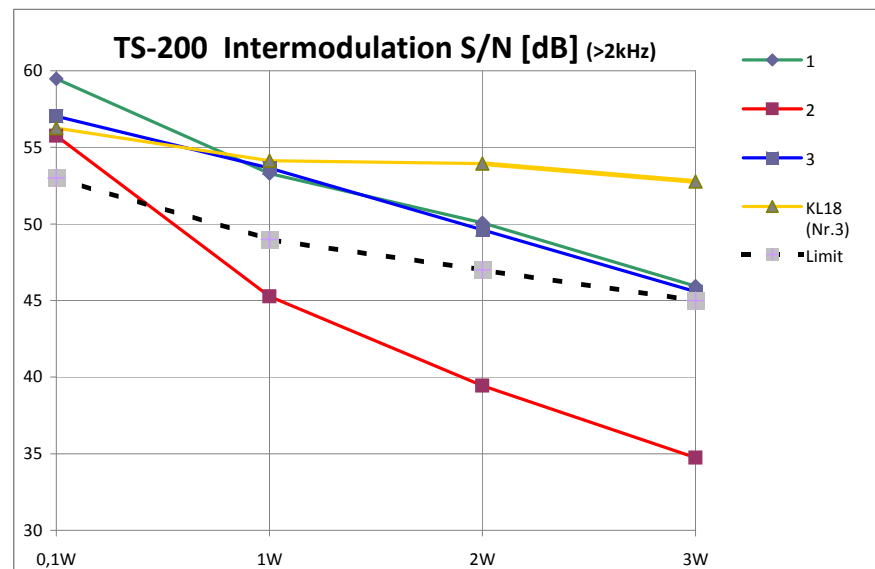

IM (550Hz+715Hz) S/N